

Pflow Series 21 Hydraulic Vertical Lift DIMENSIONS & DATA

Straddle Carriage

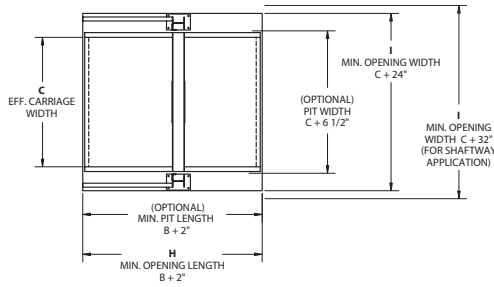

Cantilever Carriage

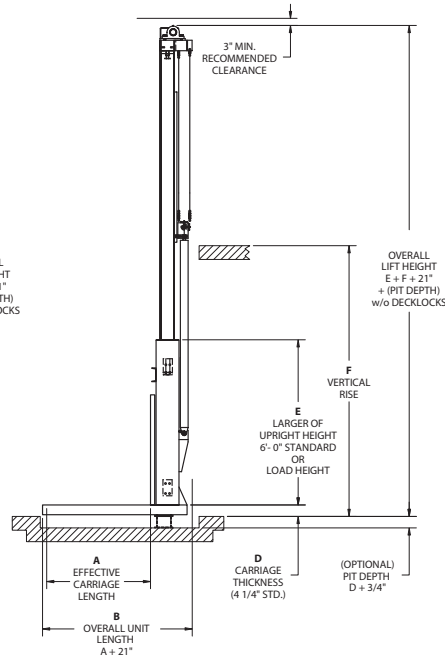
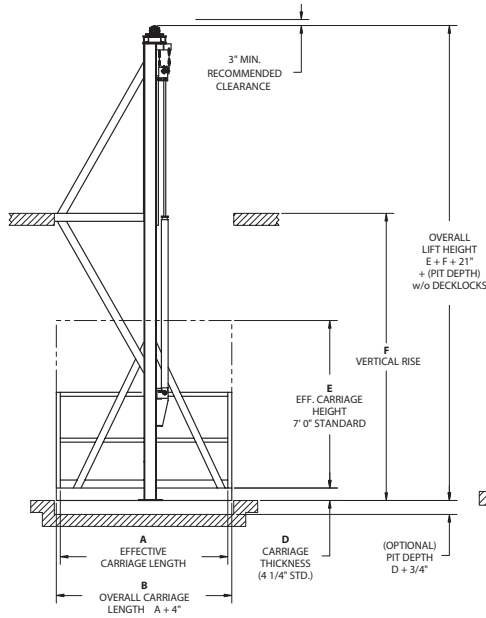
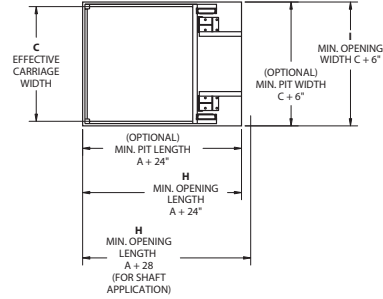

- A** Eff. Carriage Length: Load Size: W L H
- B** Overall Carriage (L): Load Weight:
- C** Eff. Carriage Width: Loads Per Hour:
- D** Carriage Thickness: Location: Interior
- E** Load Height: Exterior
- F** Vertical Rise:
- H** Upper Level Opening (Length):
- I** Upper Level Opening (Width):

- A** Eff. Carriage Length: Load Size: W L H
- B** Overall Carriage (L): Load Weight:
- C** Eff. Carriage Width: Loads Per Hour:
- D** Carriage Thickness: Location: Interior
- E** Load Height: Exterior
- F** Vertical Rise:
- H** Upper Level Opening (Length):
- I** Upper Level Opening (Width):

Note: The dimensions shown are illustrative. Request a job-specific drawing before making any building modifications.

Series 21 Hydraulic Lift Loading/Unloading Patterns:

- C-Pattern
- Z-Pattern
- 90°-Pattern

Note: All Patterns Are Reversible.

